

## LogicMachine5 Reactor IO V3

**LogicMachine (LM)** is your easiest way to program complex logic in KNX/EIB, Modbus, BACnet, EnOcean, LTE, CANx and other networks. LM will enable you to efficiently customize building automation processes, easily delivering unlimited flexibility benefit to end users in a cost-effective way.

**LM5-RIO3** is an embedded platform with integrated Ethernet, USB, KNX/EIB, CAN FT, Serial interfaces, EnOcean transceiver (optional), LTE (optional) and I/O ports. LM allows to use it as cross-standard gateway, logic engine, visualization platform, IP Router. Scripting templates provides user-friendly, flexible configuration interface and integration with cloud/web services, 3<sup>rd</sup> party devices. Via applying custom scripts LM can simultaneously act as thermostat, security panel, lighting controller, etc. LogicMachine application store and external app development possibility allows to extend device functionality and adjust to a specific market segment.

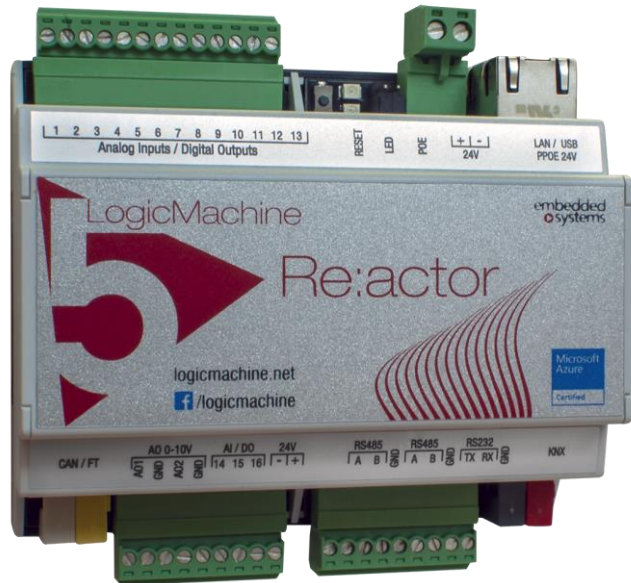

### ENG - Data sheet

Issue date 20.03.2023

## Application

- Logical functions
- WEB SCADA visualization for PC and touch-devices
- cross-standard gateway
- integration with third party devices over USB, RS485 serial port, Ethernet – AV, IR, HVAC
- Data logger with trends
- KNX IP Router
- Presence monitoring
- Lighting regulation
- Universal controller (lighting, shutter etc.)
- Health/activity monitoring
- Internet-of-Things
- Cloud server/client
- ...

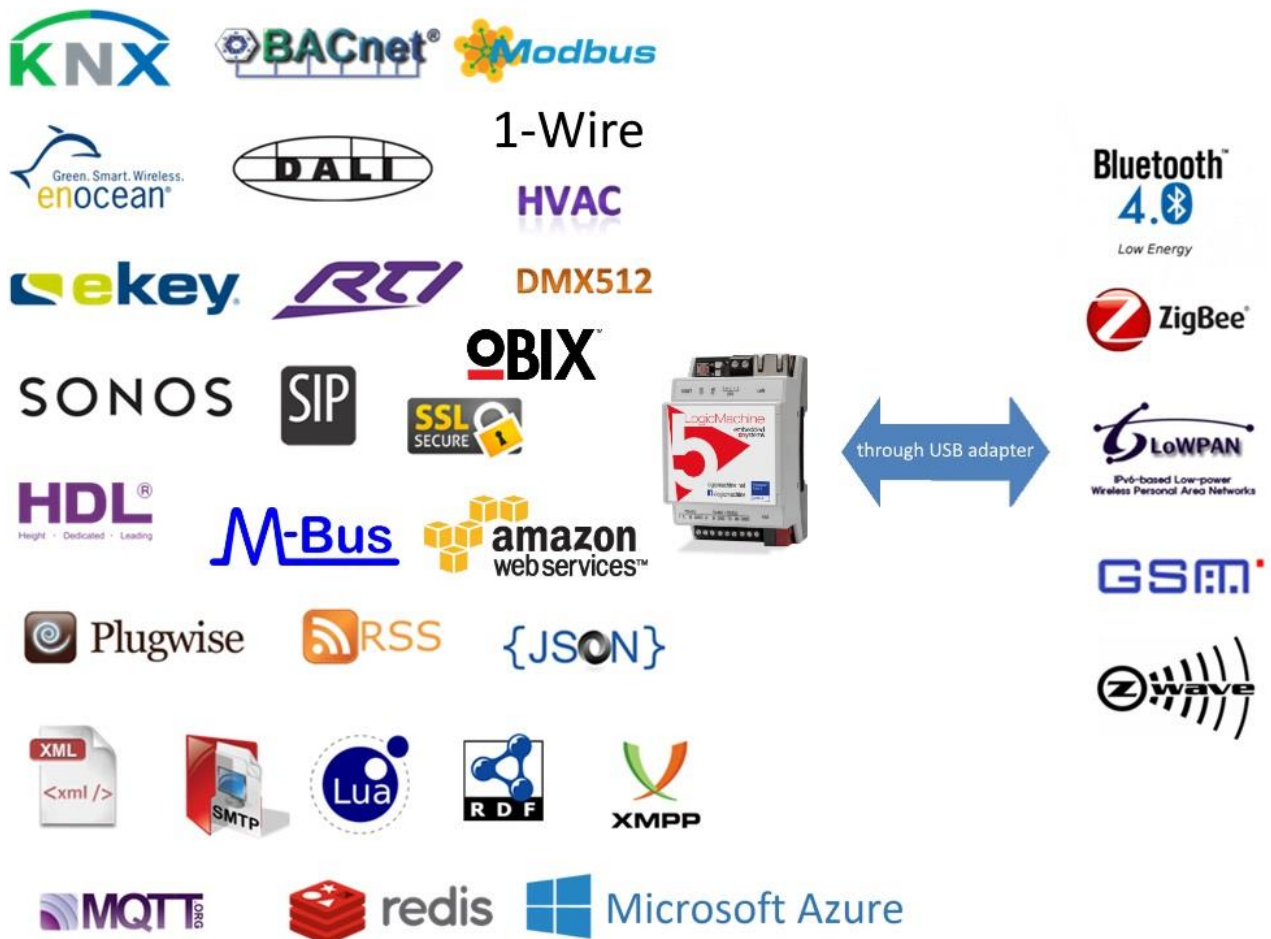

## Types of product

LogicMachine5 Reactor IO V3 Power	<b>LM5p2-RIO3</b> (with KNX TP1, CAN FT on-board)
LogicMachine5 Reactor IO V3 LTE Power	<b>LM5p2-RIO3LTE</b> (with KNX TP1, LTE modem on board, no CAN FT)
LogicMachine5 Reactor IO V3 EnOcean Power	<b>LM5p2-RIO3E</b> (with KNX TP1, EnOcean, CAN FT on-board)
LogicMachine5 Reactor IO V3 Power CANx	<b>LM5Cp2-RIO3</b> (with CAN FT on-board, no KNX TP1)
LogicMachine5 Reactor IO V3 LTE Power CANx	<b>LM5Cp2-RIO3LTE</b> (with LTE modem and CAN FT on board, no KNX TP1)
LogicMachine5 Reactor IO V3 EnOcean Power CANx	<b>LM5Cp2-RIO3E</b> (with CAN FT, EnOcean on-board, no KNX TP1)

## Standards and norms compliance

EMC:	EN61000-6-1 EN61000-6-3
PCT	Certificate

## Technical data:

Power supply:	2 x 24V DC on terminal connectors (1 for LM powering, 1 for external relay powering) or 24V DC Passive Power-over-Ethernet	
Power consumption:	1.3W	
Interface:	KNX/EIB TP1	1 (LM5p2-RIO3, LM5p2-RIO3LTE, LM5p2-RIO3E)
	CAN FT	1 (LM5Cp2-RIO3, LM5Cp2-RIO3LTE, LM5Cp2-RIO3E)
	EnOcean 868MH with Antenna	1 (LM5p2-RIO3E, LM5Cp2-RIO3E)
	10BaseT/100BaseTX	1
	RS-485	1
	RS-485/RS-232 (switchable in software – full-duplex=RS232, half-duplex=RS485)	1
	USB2.0	1
	Analog input/Digital output	16 (Configurable). 100 mA continues current on output (if all 16 ports activated).

		Optoislated from KNX/EIB bus. Additional 24V power source is supported.
	Analog outputs	2 (0-10V, 8bit resolution, 20mA max current)
	LTE modem with antenna	1 (LM5p2-RIO3LTE, LM5Cp2-RIO3LTE)
LTE modem		
	LTE FDD	B1/B3/B7/B8/B20/B28A
	WCDMA	B1/B8
	GSM	B3/B8
	<b>Data:</b>	
	<u>LTE:</u>	
	LTE FDD: Max 10Mbps (DL)/Max 5Mbps (UL)	
	<u>UMTS:</u>	
	DC-HSDPA: Max 42Mbps (DL)	
	HSUPA: Max 5.76Mbps (UL)	
	WCDMA: Max 384Kbps (DL)/Max 384Kbps (UL)	
	<u>GSM:</u>	
	EDGE: Max 296Kbps (DL)/Max 236.8Kbps (UL)	
	GPRS: Max 107Kbps (DL)/Max 85.6Kbps (UL)	
Connections:	KNX bus:	Bus Connection Terminal 0.8mm <sup>2</sup>
	Power supply:	Screw, 1.5mm <sup>2</sup>
	Serial:	Screw, 1.0 mm <sup>2</sup>
	I/O:	Screw, 1.5 mm <sup>2</sup>
	1-wire	Screw, 1.5 mm <sup>2</sup>
Operating elements	LED	1 – CPU load 1 - Activity
Enclosure:	Material:	Polyamide
	Color:	Gray
	Dimensions:	61(W)x90(H)x108(L) mm
Usage temperature:	0C ... +45C	
Storage temperature:	-15C ... +55C	
Weight:	150g	
Warranty:	2 years	
Relative Humidity:	10...95 % without condensation	



## Caution

## Security advice

The installation and assembly of electrical equipment may only be performed by skilled electrician. The devices must not be used in any relation with equipment that supports, directly or indirectly, human health or life or with application that can result danger of people, animals or real value

## Electrical connection

The devices are constructed for the operation of protective low voltage (SELV). Grounding of device is not needed. When switching the power supply on or off, power surges must be avoided.

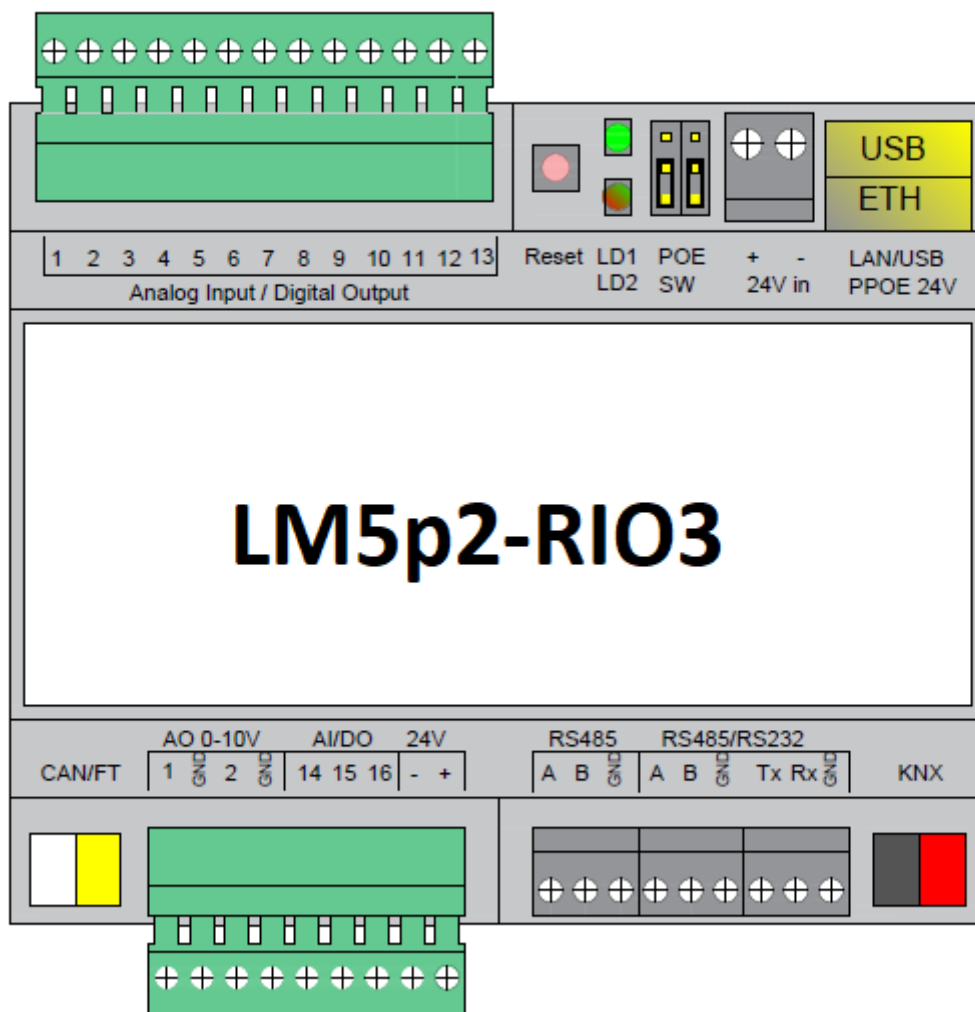

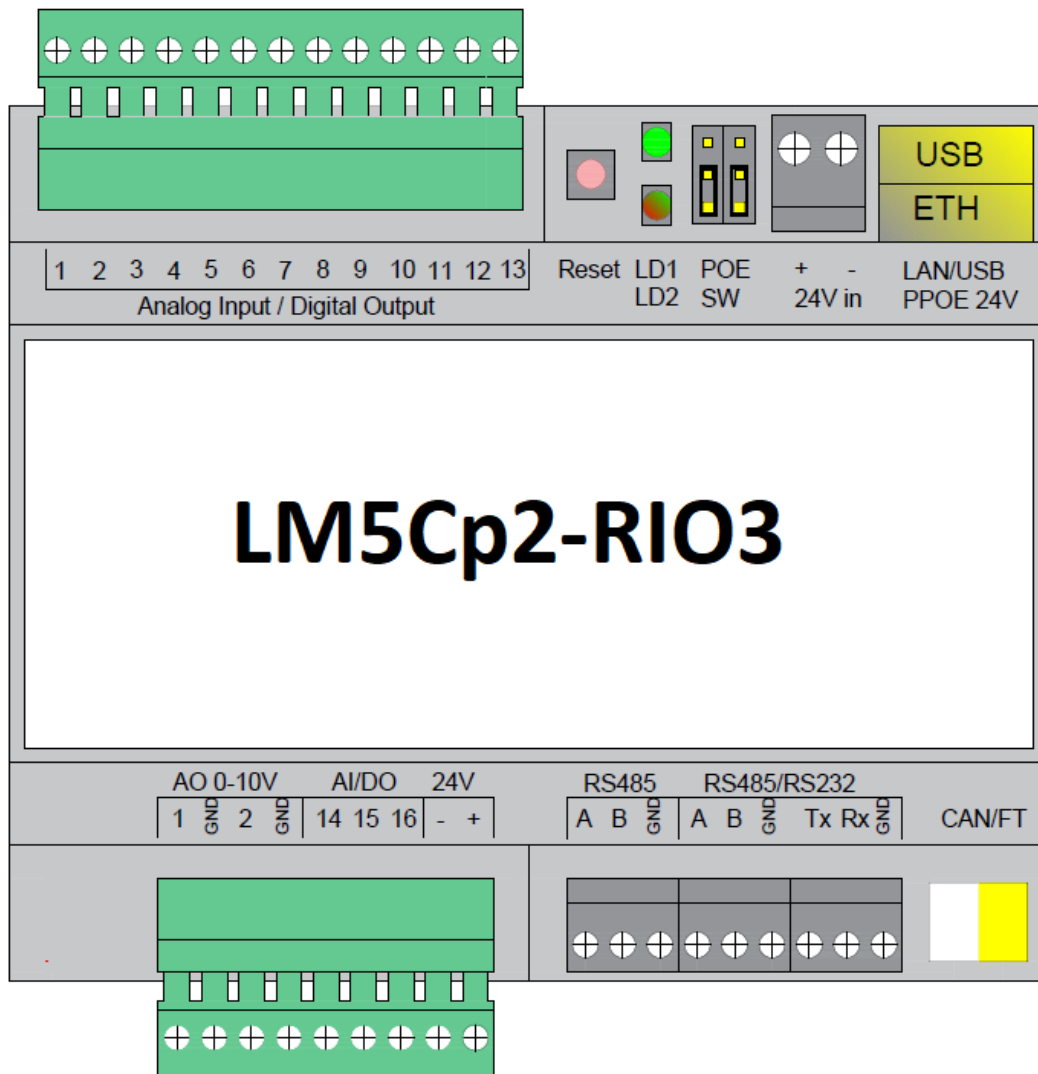



# Terminal connection schemes

## Powering over Ethernet

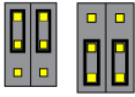
LM5 supports two powering modes:

- regular powering over screw terminals (Jumpers up or down) 
- passive PoE powering over 24V DC (Jumpers down) 
- when using active PoE 48V, jumpers have to be UP or the product **will be damaged!**

Please note that there are two PoE types of PoE switches/adapters – passive and active (802.3af). In passive mode 4 Ethernet cable wires are used for data and 4 are used for power. In active PoE mode data and power goes together.

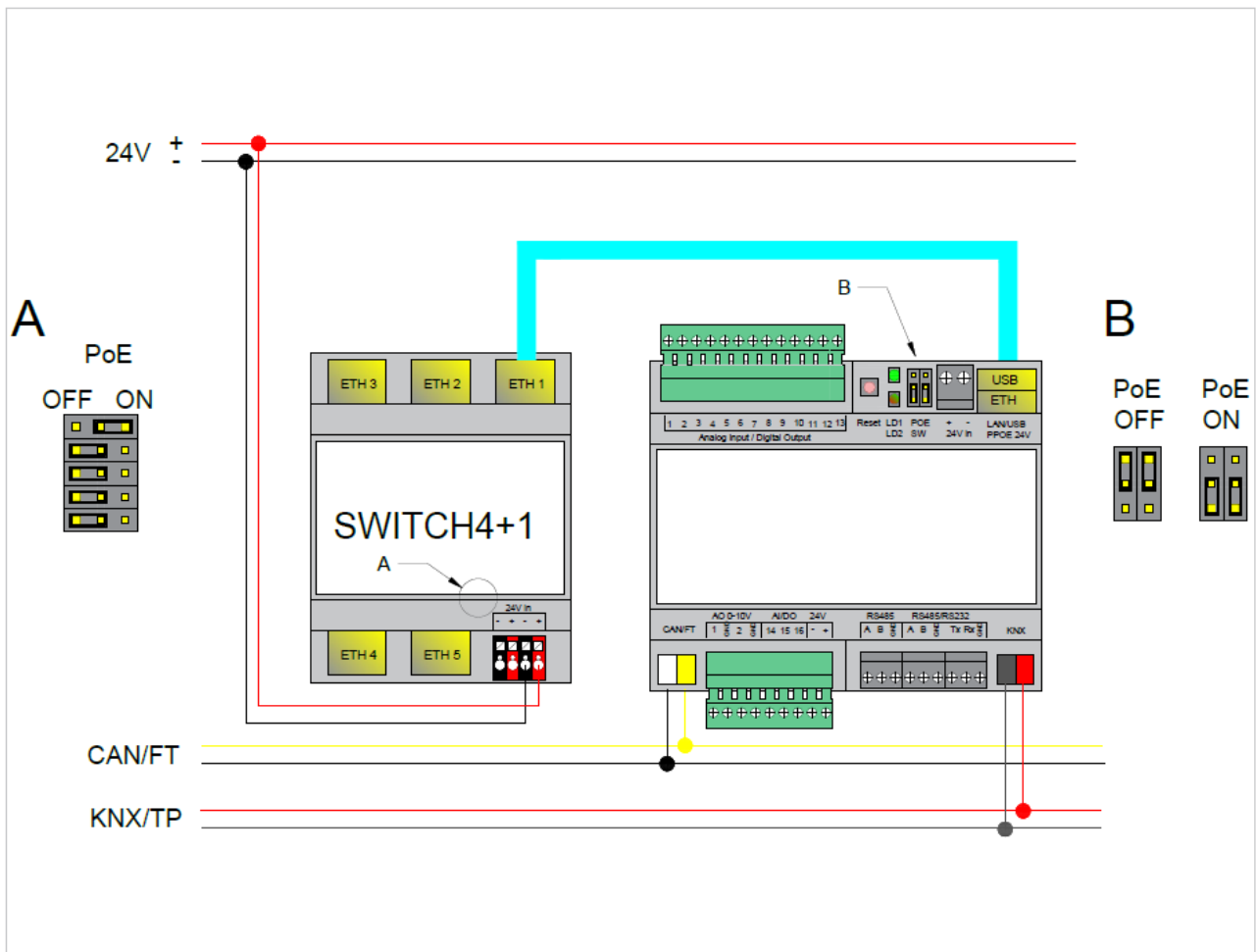

## Passive PoE switch



## Passive PoE adapters





## RS-485 connection

There can be used max two RS-485 on LM5. First one is definitive, second one is software switchable – either it works as RS-485 or as RS-232 :

- If it is set up as full-duplex it will operate as RS-232 and respective TX/RX/GND screw terminals should be used
- If it is set up as half-duplex (\*) it will operate as RS-485 and respective A/B/GND screw terminals should be used

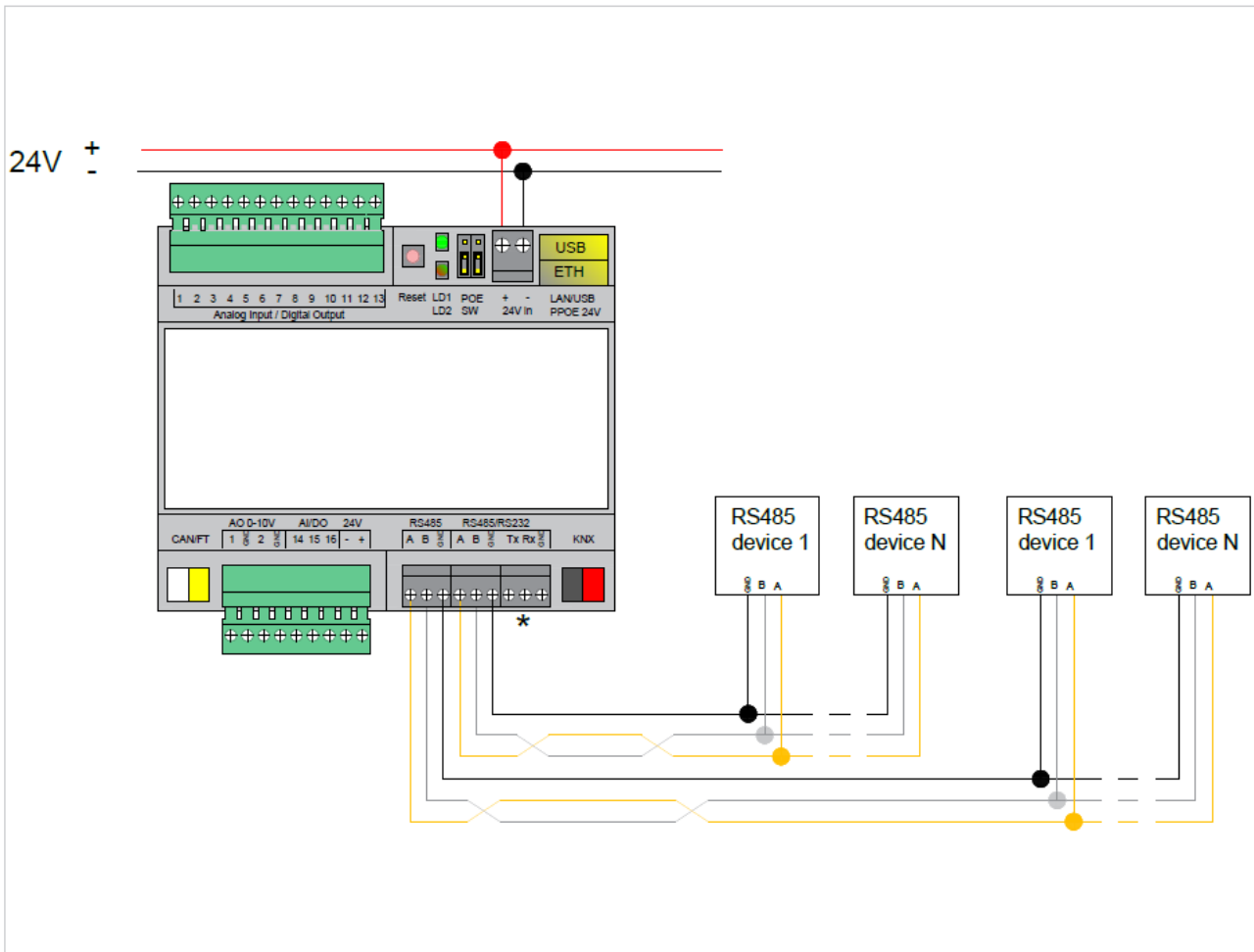

\*RS-485 is chosen in this case, RS-232 is not activated

## RS-485/RS-232 connection

If second serial port is set as full-duplex in LogicMachine configuration, it will operate as RS-232 and respective TX/RX/GND screw terminals should be used.

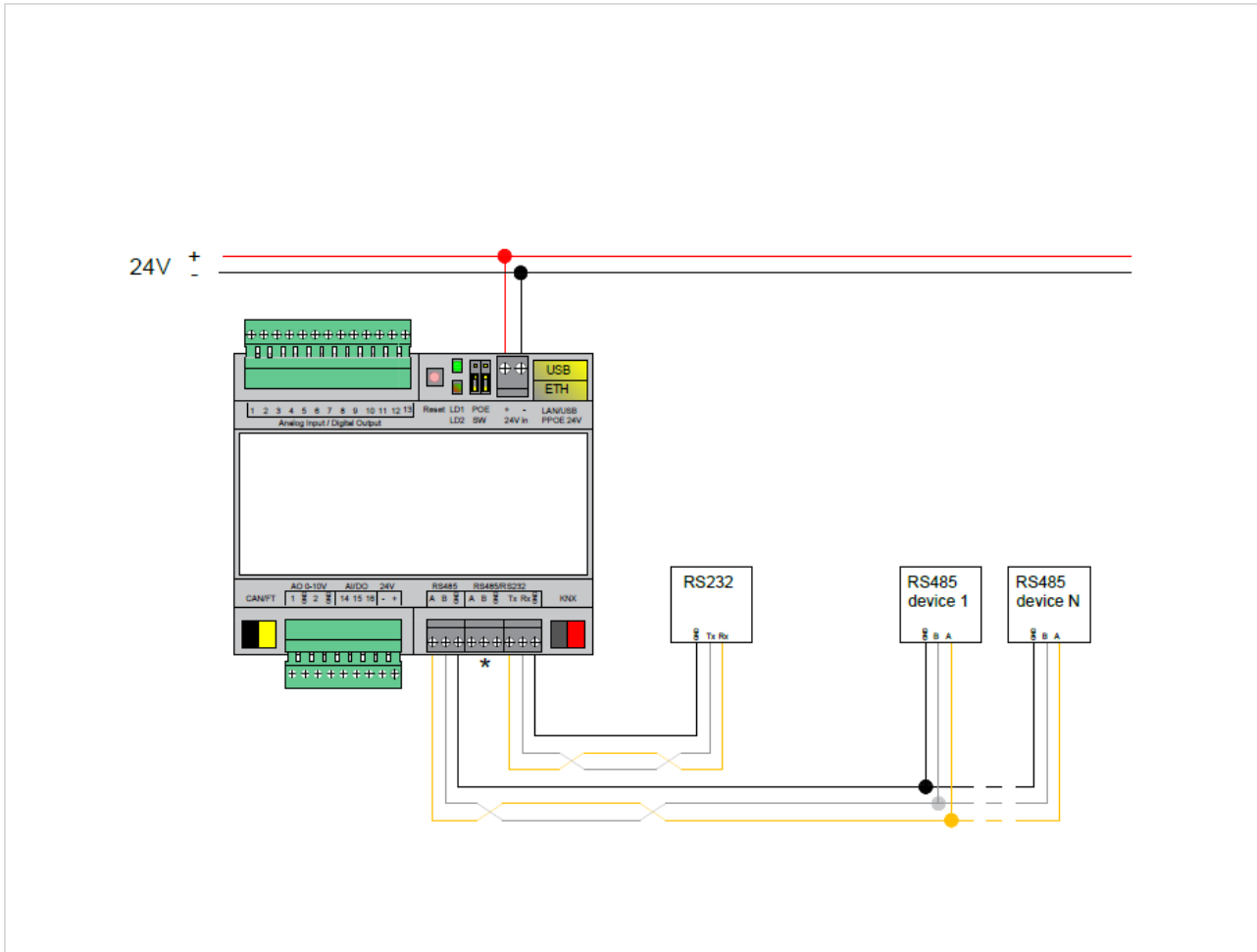

\*RS-232 is chosen in this case, RS-485 is not activated

## Digital output (e.g. relay/contactor)

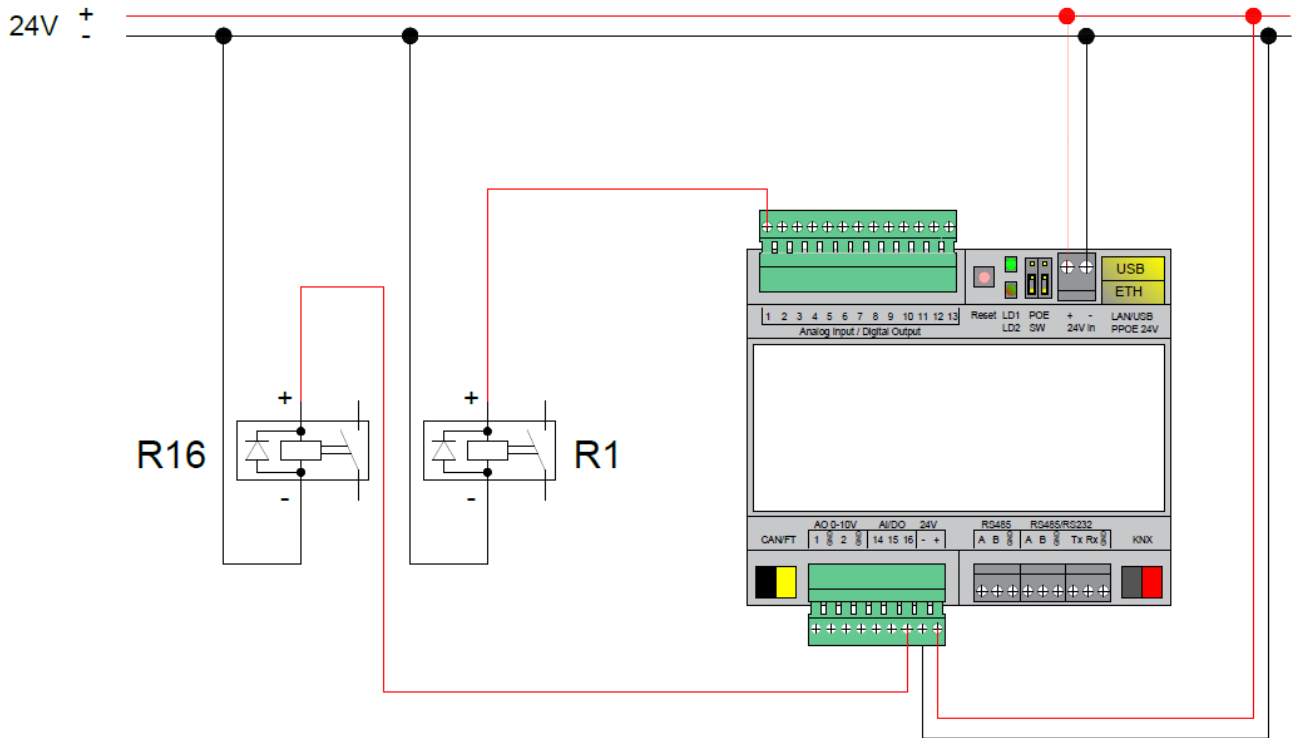

## Binary input (e.g. pushbutton) or Analog input

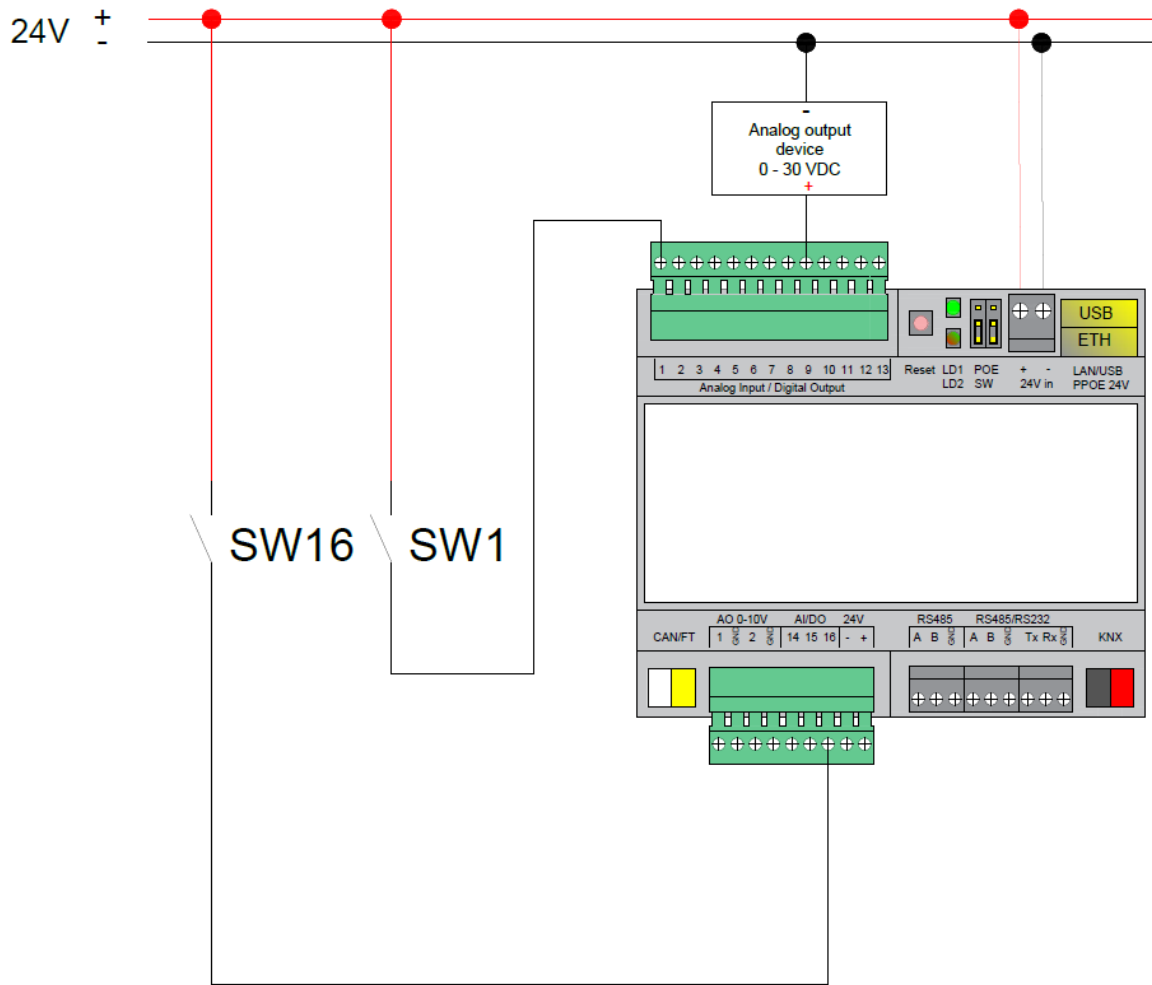

## Analog output (0..10V)

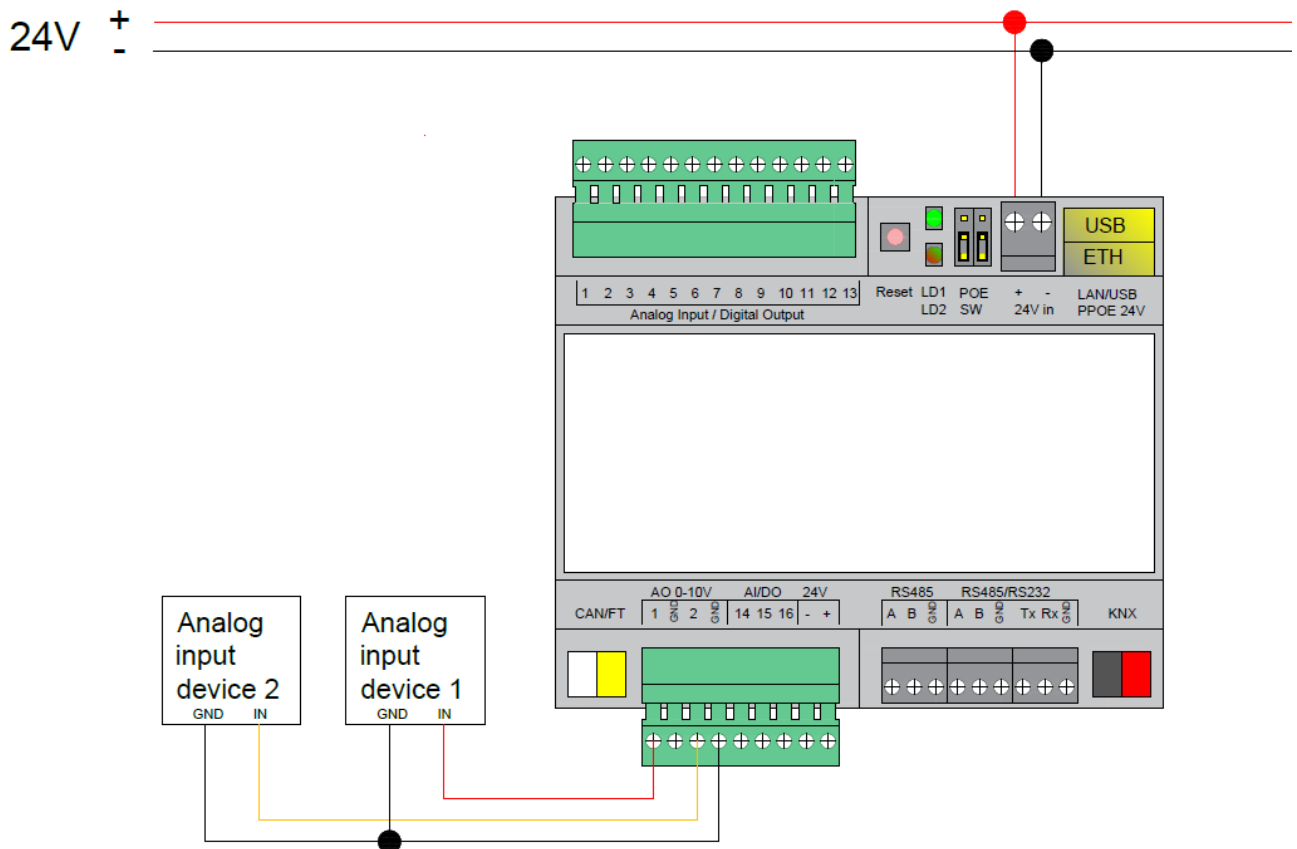

# CAN FT connection

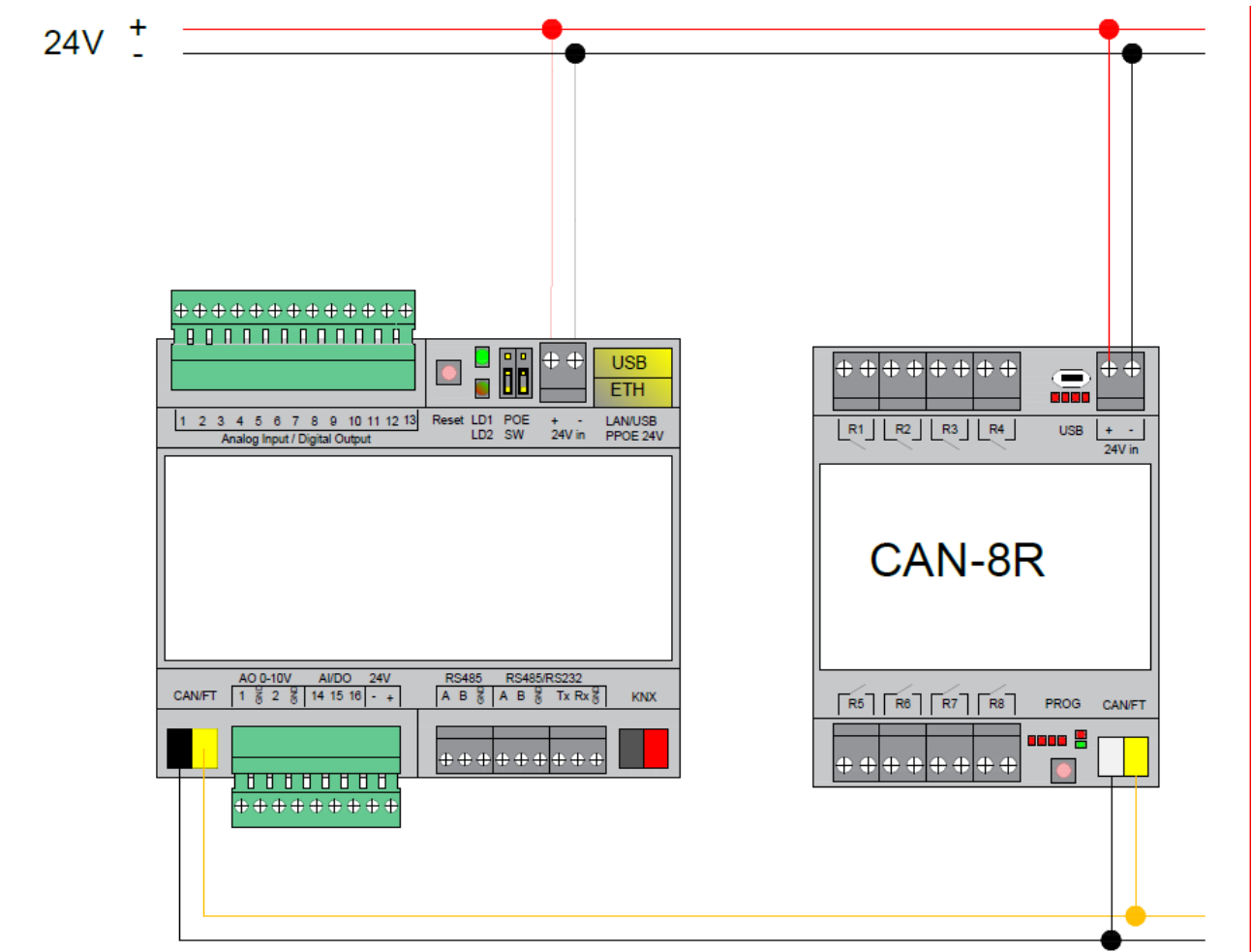

## Quick startup guide

- 1) Mounting the device on DIN rail
- 2) Connect the KNX bus cable
- 3) Connect 24V power supply to the device (either through separate 24V crew terminals or through Passive 24V DC Power-Over-Ethernet)
- 4) Connect Ethernet/LAN cable coming from the PC/switch

## Default IP configuration

Login name	admin
Password	admin
IP address	192.168.0.10
Network mask	255.255.255.0

## Reset device

You can either reboot the device by pressing RESET button or reset the configuration to factory defaults:

- *Press and hold for <10 sec* – reboot the device
- *Press and hold for >10 sec* – reset networking with IP to factory default
- *Press and hold for >10 sec and again press and hold for >10 sec* – full reset of configuration to factory defaults